

Operating Instructions Functional Manual

Interface Board for 12G-SDI Optical Commercial Use

Model No. **ET-MDNFB10**

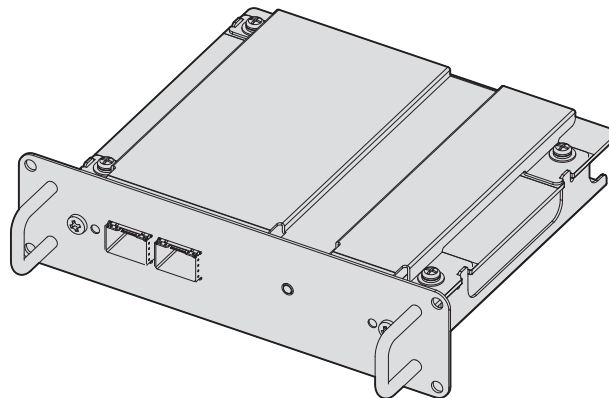

Thank you for purchasing this Panasonic product.

- Before using this product, please read these “Operating Instructions” and the “Operating Instructions” of the projector carefully and save the manuals for future use.
- Before using this product, be sure to read “Read this first!” (➡ page 3).

4K
PROFESSIONAL

ENGLISH

DPQP1310ZD/X1

Contents

Read this first!	3
Precautions for use	4
Supported projector	4
Supported SFP module	4
Handling of the product	4
Disposal	5
Accessories	5
Part names and functions	5
Installing the Interface Board	7
Before installing or removing the Interface Board	7
How to install the Interface Board	7
How to remove the Interface Board	8
Installing the SFP module	9
How to install the SFP module	9
How to remove the SFP module	9
Connecting example	11
Selecting the input signal	12
Switching the input directly	12
Switching the input by displaying the input selection screen	12
Menu navigation	13
[BACKUP INPUT SETTING]	13
[SLOT IN]	14
[SECONDARY INPUT]	16
[STARTUP INPUT SELECT]	17
[SCHEDULE]	17
[REMOTE2 MODE]	19
[MULTI DISPLAY]	19
[CONTROL DEVICE SETUP]	20
Appendix	22
Troubleshooting	22
Control command	22
List of compatible signals	23
Specifications	26

Read this first!

WARNING:

Do not spill water on this product or allow this product to get wet.

Doing so may cause electric shock, fire, or malfunction due to short circuit or overheating.

- Do not place a container with liquid close to this product.
- Consult your dealer when liquid such as water is spilled on this product.

Do not place the supplied port covers and screws in a location that a child can reach.

Accidentally swallowing them can cause a physical harm.

- Seek a medical advice immediately if a child might have swallowed them.

Do not disassemble or modify.

Doing so may cause electric shock or fire. It may also cause a malfunction.

CAUTION:

Do not place this product in a location with excessive humidity or dust, or in a location exposed to oil smoke or steam.

Doing so may cause fire or electric shock.

Do not place this product in extremely hot location.

Doing so may deteriorate the part, or may cause fire.

- Do not install or store in a location with direct sunlight or close to the heating device, etc.

Disconnect the power plug from the wall outlet before installing or removing this product to/from the projector.

Failure to do so may cause electric shock.

The SFP module to be attached to this product is a Class 1 laser product. Do not look at the SFP module or the connector of the optical fiber cable while the projector is turned on. The laser beam may enter the eyes and cause damage to the eyes.

Precautions for use

This product is a 12G-SDI signal compatible Interface Board equipped with two ports that can install the SFP (Small Form-Factor Pluggable)/SFP+ module (referred to as “SFP module” hereinafter). By installing this product to the projector manufactured by Panasonic Projector & Display Corporation, long-distance transmission of the SDI signal via optical fiber cable will be possible without a separate converter to convert from optical signal to electric signal.

Supported projector

This product can be used with following projectors. However, this product cannot be used if the main version of the firmware of the projector is earlier than the following compatible firmware version. Use the product after updating the projector to the latest firmware.

Supported projector	Compatible firmware version (Main version)
PT-RQ50K	2.00 or later
PT-RQ32K	4.00 or later
PT-RQ22K	4.04 or later*1
PT-RCQ10, PT-RCQ80	2.00 or later

*1 The <SDI OPT 1/2 OUT> terminal cannot be set as output if using PT-RQ22K with the main version of the firmware earlier than 4.06.

For details of output setting, refer to the [DISPLAY OPTION] menu → [SLOT IN] → [SDI OPT 1/2 OUT].

(As of March 2020)

Note

- This manual omits the alphabets at the end of projector model numbers.
- This product may support the projectors that are not described in the table. Confirm the “Operating Instructions” of the projector. The “Operating Instructions” can be found on the following URL.
<https://docs.connect.panasonic.com/projector>
- The main version of the firmware can be confirmed in the on-screen menu of the [PROJECTOR SETUP] menu → [STATUS].
- For the update procedure of the firmware, access the latest information regarding the firmware in the PASS website (<https://docs.connect.panasonic.com/projector/pass>). It is necessary to register and login to PASS*1 to access the PASS website.

*1 PASS: Panasonic Professional Display and Projector Technical Support Website

Supported SFP module

The 12G-SDI/6G-SDI/3G-SDI/HD-SDI compatible optical fiber SFP module that is compliant with MSA (Multi-Source Agreement), and the optical fiber SFP module that the operation has been verified with the projector manufactured by Panasonic Projector & Display Corporation.

- Receiver (for receiving)
- Transmitter (for sending)
- Transceiver (for sending and receiving)

Note

- Operation of the sending function is restricted depending on the port where the SFP module is installed.
- Prepare the commercially available SFP module and the optical fiber cable required for connection according to the usage, video signal to be input, specification of the external device to be connected, etc.
- The SFP module that the operation has been verified with the projector manufactured by Panasonic Projector & Display Corporation can be confirmed from the following URL.
<https://docs.connect.panasonic.com/projector>
Confirmation of operation for SFP module from other manufacturer has been performed with the items set independently by Panasonic Projector & Display Corporation, and not all the operations are warranted. For operation or performance problems caused by the SFP module, contact the respective manufacturers.

Handling of the product

■ Do not touch the connector section of the Interface Board directly with your hands

The component may be damaged by the static electricity. Before handle this product, remove the charge in the body by touching the surrounding metal, etc.

■ Do not look into the connector of the SFP module.

The SFP module to be installed on this product is a Class 1 laser product. Do not look into the SFP module or the connector of the optical fiber cable with the power of the projector turned on. Your eyes may be damaged when the laser goes into your eyes.

Disposal

To dispose of the product, ask your local authorities or dealer for correct methods of disposal.

Accessories

Make sure that the following accessories are provided with the product. Numbers enclosed in < > show the number of accessories.

Port cover <2>
(DVHR1128ZA/X1)

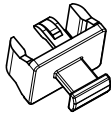

Screw <4>
(XSB3+8FN)



(Attached to the product at the time of purchase)

Attention

- After unpacking the product, discard the packaging material properly.
- For missing accessories, consult your dealer.
- Store small parts in an appropriate manner, and keep them away from small children.

Note

- Supplied screws are spare parts. Use them when the screws to fix the slot cover of the projector are lost.
- The model numbers of accessories are subject to change without prior notice.

Part names and functions

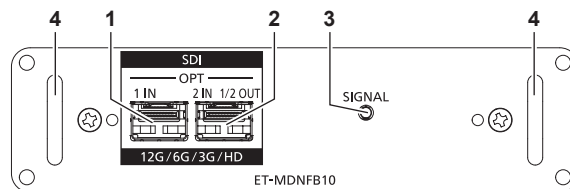

- 1 **SFP port 1**
This is the port to install the SFP module for receiving.
- 2 **SFP port 2**
This is the port to install the SFP module for sending and receiving.

- 3 **Input indicator <SIGNAL>**
This is the indicator to indicate the detection state of the video signal. This is illuminated when input of the video signal is detected in either or both of the <SDI OPT 1 IN> terminal and the <SDI OPT 2 IN> terminal.
- 4 **Handle**

Note

- The sending function of the SFP module for sending or for sending and receiving will not operate when it is installed in the SFP port 1.
- In addition to the SFP module for sending and receiving, the SFP module for receiving or for sending can be installed in the SFP port 2.

■ When the SFP modules are installed

This is an example when the SFP module for receiving (LC connector) is installed in the SFP port 1, and the SFP module for sending and receiving (LC connector) is installed in the SFP port 2.

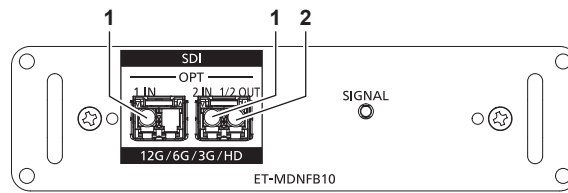

1 <SDI OPT 1 IN> terminal/<SDI OPT 2 IN> terminal
These are terminals to input SDI signal (optical signal).

2 <SDI OPT 1/2 OUT> terminal
This is an active through terminal to output the signal input to the <SDI OPT 1 IN> terminal/<SDI OPT 2 IN> terminal.

Note

- The input signal to the <SDI OPT 1 IN> terminal or the <SDI OPT 2 IN> terminal that is selected for input is output from the <SDI OPT 1/2 OUT> terminal.

Installing the Interface Board

Requesting a qualified technician to install or remove the Interface Board to the projector is recommended. A malfunction may occur due to static electricity. Consult your dealer.

Before installing or removing the Interface Board

- Always turn off the power of the projector before installing or removing the Interface Board.
 - When turning off the projector, make sure to follow the procedures described in the “Operating Instructions” of the projector.
- Do not touch the connector section of the Interface Board directly with your hands.
 - The component may be damaged by the static electricity.
- Remove the static electricity from your body by touching to surrounding metal, etc., in advance to prevent the static electricity damage.
- Take care not to get injured when installing or removing the Interface Board.
 - Hands may be injured by the opening of the empty slot of the projector, the edge of the bracket of the Interface Board, socket of the SFP port, etc.
- When installing the Interface Board to the slot, insert it into the connector straight and slowly.
 - It may not operate or cause malfunction if it is not correctly installed.
- The illustrations in the procedure are examples when installing the Interface Board in PT-RQ22K.

How to install the Interface Board

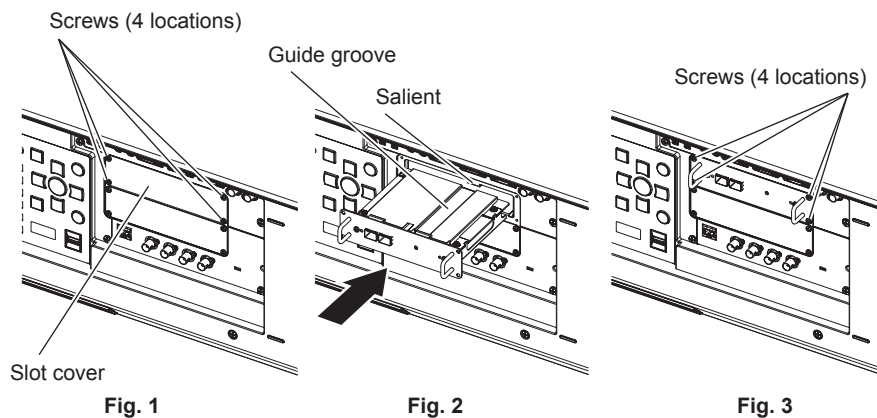

1) Remove the slot cover. (Fig. 1)

- Remove the four screws fixing the slot cover of the projector by rotating counterclockwise with a Phillips screwdriver. The removed screws are used to fix the Interface Board.
- When removing the fourth screw, hold the slot cover with your hand so it will not fall.
- To replace from other Interface Board, remove the Interface Board following the procedure in “How to remove the Interface Board” (➡ page 8).

2) Install the Interface Board to the projector. (Fig. 2)

- Insert the guide groove of the Interface Board aligned to the salient of the slot. Insert the bracket firmly all the way in.

3) Fix the Interface Board. (Fig. 3)

- Tighten and fix with the four screws removed in Step 1).

Attention

- The removed slot cover is required when the unnecessary Interface Board is removed. Store it so it can be attached in the future.

How to remove the Interface Board

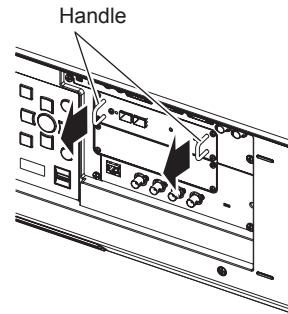

Fig. 1

1) Remove the Interface Board. (Fig. 1)

- Remove the four screws fixing the Interface Board by rotating counterclockwise with a Phillips screwdriver. The removed screws are used to fix the slot cover.
- Hold the handle of the Interface Board and remove it slowly.

2) Attach the slot cover.

- Attach the stored slot cover to the empty slot, and tighten and fix with the four screws removed in Step 1).

Attention

- Always attach the slot cover on the empty slot.
- Store the removed Interface Board inside an antistatic bag.

Installing the SFP module

This section explains an example of a procedure to install and remove the SFP module. Please also check the operating instructions and setup guide of the SFP module to be installed.

How to install the SFP module

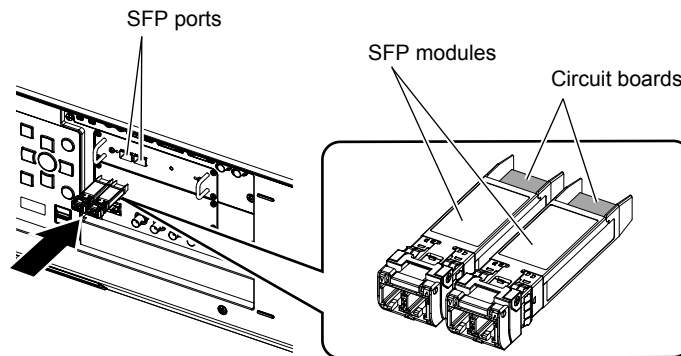

Fig. 1

- 1) **Remove the port cover.**
 - Pull out the port cover of the SFP port.
- 2) **Install the SFP module to the SFP port. (Fig. 1)**
 - With the circuit board of the SFP module visible from the top, securely insert the SFP module all the way.
 - Remove the protection cap on the <SDI OPT 1 IN> terminal, <SDI OPT 2 IN> terminal, or <SDI OPT 1/2 OUT> terminal, if there is any, before using.

Attention

- The removed port cover and the protection cap will be needed in following cases. Store them so that they can be attached in the future.
 - When the SFP module not required anymore is removed
 - When there is a terminal not to be used
 - When storing the SFP module

How to remove the SFP module

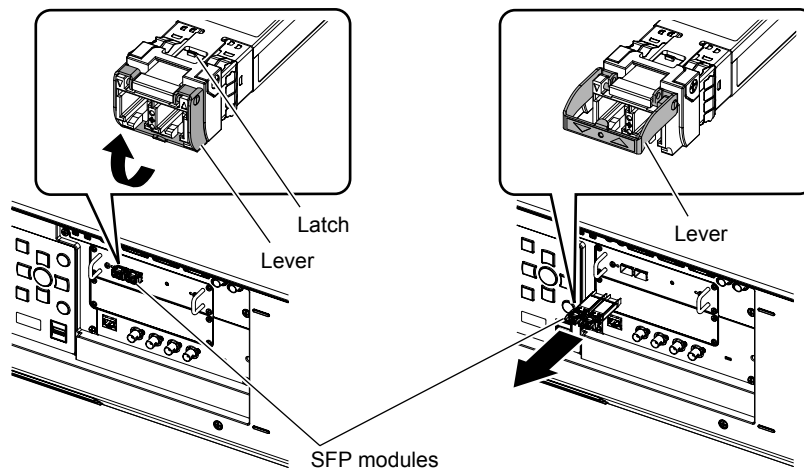

Fig. 1

Fig. 2

- 1) **Disconnect the optical fiber cable.**
 - If the optical fiber cable is connected to the SFP module, remove the cable while releasing the latch of the optical fiber cable.
- 2) **Release the latch of the SFP module. (Fig. 1)**
 - Pull up the lever on the SFP module to release the latch.

3) Remove the SFP module. (Fig. 2)

- Hold the lever and slowly pull out the SFP module.

Attention

- Make sure to attach the port cover on the SFP port that the SFP module is not installed.
- Store the removed SFP module with the protection cap, etc., attached so that dust does not accumulate or the SFP module does not get dirty.

Connecting example

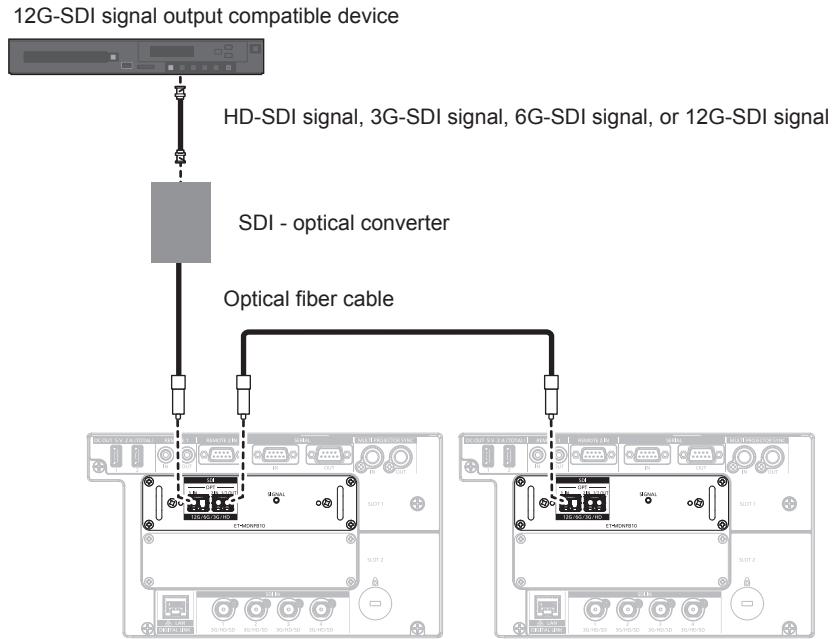

Note

- Prepare the commercially available SFP module and the optical fiber cable required for connection according to the usage, video signal to be input, specification of the external device to be connected, etc.
- The transmission distance may become shorter and the image may not display correctly when there is dust on the connector of the SFP module or optical fiber cable, or it is dirty. Attach the protection cap or cover supplied by each product to the connector of the SFP module or the optical fiber cable if the optical fiber cable is not connected.

Selecting the input signal

The method to switch the input of the image to project is as follows.

- Press the input selection button on the remote control or the control panel of the projector and directly specify the input of the image to project.
- Display the input selection screen and select the input of the image to project from the list.

Switching the input directly

The input of the image to project can be switched by directly specifying it with the input selection button on the remote control or the control panel of the projector.

1) Press the <SLOT 1> button, <SLOT 2> button, or <SLOT> button.

<SLOT 1>*1	Switches to the input of this Interface Board installed in <SLOT 1>. The input is switched every time the button is pressed when one of the inputs is selected on the installed Interface Board.
<SLOT 2>*1	Switches to the input of this Interface Board installed in <SLOT 2>. The input is switched every time the button is pressed when one of the inputs is selected on the installed Interface Board.
<SLOT>*2	Switches to the input of this Interface Board installed in <SLOT>. The input is switched every time the button is pressed when one of the inputs is selected on the installed Interface Board.

*1 For the projector equipped with two slots

*2 For the projector equipped with only one slot

Note

- If the SFP module for receiving or for sending and receiving is not installed in the SFP port, the input will be treated as the status that there is no input signal.
- The operation when the <SLOT 1> button, <SLOT 2> button, or <SLOT> button is pressed can be fixed to the operation to switch to the specified input using the [SECURITY] menu → [CONTROL DEVICE SETUP].

Switching the input by displaying the input selection screen

The input of the image to project can be selected by displaying the input selection screen.

1) Press the <INPUT MENU> button on the remote control or the control panel of the projector.

- The input selection screen is displayed.

Following input selection screen is an example when the Interface Boards are installed in <SLOT 1> and <SLOT 2> of PT-RQ22K.

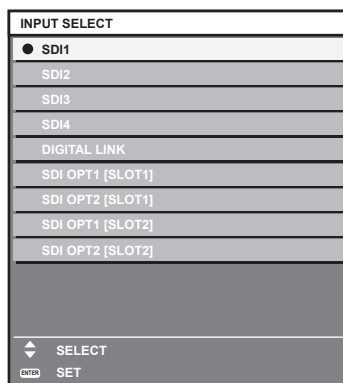

2) Press the <INPUT MENU> button again.

- The input will switch each time you press the <INPUT MENU> button.

Note

- Input can be switched by pressing ▲▼ to select the input of the image for projection and pressing the <ENTER> button while the input selection screen is displayed.
- If the SFP module for receiving or for sending and receiving is not installed in the SFP port, the input will be treated as the status that there is no input signal.

Menu navigation

This section explains about the on-screen menu (menu screen) that can be operated by installing this Interface Board in the slot of the projector.

For the menu items with ✓ in the following table, the additional explanation for the target model is described. Refer to the explanation together with the “Operating Instructions” of the projector.

Main menu item	Detailed menu item	PT-RQ50K	PT-RQ32K	PT-RQ22K	PT-RCQ10 PT-RCQ80
[DISPLAY OPTION]	[BACKUP INPUT SETTING]	✓	✓	✓	—
	[SLOT IN]	✓	✓	✓	✓
[PROJECTOR SETUP]	[BACKUP INPUT SETTING]*1	✓	—	—	—
	[SECONDARY INPUT]	✓	—	—	✓
	[STARTUP INPUT SELECT]	✓	✓	✓	✓
	[SCHEDULE]	✓	✓	✓	✓
	[REMOTE2 MODE]	✓	✓	✓	✓
[MULTI DISPLAY]	—	—	✓	✓	—
[SECURITY]	[CONTROL DEVICE SETUP]	✓	✓	✓	✓

*1 The setting item of the [PROJECTOR SETUP] menu → [NO SIGNAL SETTING] → [BACKUP INPUT SETTING] is common with the following menu item.
The [DISPLAY OPTION] menu → [BACKUP INPUT SETTING]

Note

- This document explains mainly for the operation regarding the input to this Interface Board.

[BACKUP INPUT SETTING]

Set the backup function that switches the signal to the backup input signal as seamless as possible when input signal is disrupted.

- 1) Select [DISPLAY OPTION] from the main menu.
- 2) Press the <ENTER> button.
 - The [DISPLAY OPTION] screen is displayed.
- 3) Press ▲▼ to select [BACKUP INPUT SETTING].
- 4) Press the <ENTER> button.
 - The [BACKUP INPUT SETTING] screen is displayed.
- 5) Press ▲▼ to select [BACKUP INPUT MODE].
- 6) Press the <ENTER> button.
 - The [BACKUP INPUT MODE] screen is displayed.
- 7) Press ▲▼ to select the combination of the input and press the <ENTER> button.

Primary input	Secondary input	Number of signals constructing one screen	Details
	[OFF]	—	Disables the backup function.
[SDI OPT1 [SLOT1]]*1	[SDI OPT1 [SLOT2]]*1	1	Enables the backup function.

*1 This is displayed when these Interface Boards are installed in <SLOT 1> and <SLOT 2>.

- 8) Press the <MENU> button.
 - The [BACKUP INPUT SETTING] screen is displayed.
- 9) Press ▲▼ to select [AUTOMATIC SWITCHING].
 - When [BACKUP INPUT MODE] is set to [OFF], [AUTOMATIC SWITCHING] cannot be selected.
- 10) Press ◀▶ to switch the item.
 - The items will switch each time you press the button.

Menu navigation

[ENABLE]	Switches to the secondary input (primary input) automatically when the input signal for primary input (secondary input) is disrupted.
[DISABLE]	Disables the automatic input switching function.

Note

- The backup function is enabled when [BACKUP INPUT MODE] is set to anything other than [OFF] and same signal is input to the primary input and the secondary input.
- To switch to the backup input signal using the backup function, make sure that the following three conditions are satisfied to be ready to use the function.
 - Set [BACKUP INPUT MODE] to anything other than [OFF].
 - Input the same signal to the primary and secondary inputs.
 - Display the image of the primary input or secondary input.
- If the input is switched to other than the primary or secondary input while the backup function is ready for use, the state of readiness to use the backup function is canceled. To switch to the backup input signal using the backup function again, switch to the primary input or secondary input.
- When [BACKUP INPUT MODE] is set to anything other than [OFF], the combination of that input is displayed in [PRIMARY INPUT] and [SECONDARY INPUT] of the **[BACKUP INPUT SETTING]** screen.
- When [BACKUP INPUT MODE] is set to anything other than [OFF], [BACKUP INPUT STATUS] is displayed in the input guide and the **[STATUS]** screen.
When the signal can be switched to the backup input signal using the backup function, [ACTIVE] is displayed in [BACKUP INPUT STATUS]. When it is not possible, [INACTIVE] is displayed instead.
The secondary input will be the backup input when [BACKUP INPUT STATUS] is displaying [ACTIVE] while the image from the primary input is displayed.
The primary input will be the backup input when [BACKUP INPUT STATUS] is displaying [ACTIVE] while the image from the secondary input is displayed.
- When [BACKUP INPUT MODE] is set to anything other than [OFF], the input is switched seamlessly if the input is switched between the primary input and the secondary input while it is possible to switch to the backup input signal.
- When [AUTOMATIC SWITCHING] is set to [ENABLE], and [BACKUP INPUT STATUS] shows [ACTIVE], the signal is switched to the backup input if a disruption occurs in the input signal.
- When [AUTOMATIC SWITCHING] is set to [ENABLE], the indication in [BACKUP INPUT STATUS] will change to [INACTIVE] if the input signal is disrupted and automatically switched to the backup input. In this case, it is not possible to switch to the backup input signal until the original input signal is restored. If the input has switched to the backup input automatically, it is possible to switch to the backup input signal when the original signal has restored. In this case, the current input is maintained.
- The primary input setting values are applied to image adjustment values such as the [PICTURE] menu → [PICTURE MODE], [GAMMA], and [COLOR TEMPERATURE].

[SLOT IN]

Set this item according to the input and output signals when this Interface Board is installed in the slot.

Setting [SDI OPT 1/2 OUT] in [SLOT IN] (OPT input)

Set whether or not to output the signal from the <SDI OPT 1/2 OUT> terminal.

- 1) Select **[DISPLAY OPTION]** from the main menu.
- 2) Press the <ENTER> button.
 - The **[DISPLAY OPTION]** screen is displayed.
- 3) Press ▲▼ to select **[SLOT IN]**.
- 4) Press the <ENTER> button.
 - The **[SLOT IN]** screen is displayed.
- 5) Press ▲▼ to select **[SDI OPT 1/2 OUT]**.
- 6) Press ◀▶ to switch the item.
 - The items will switch each time you press the button.

[ENABLE]	Select this item when the input signal to the <SDI OPT 1 IN> terminal or the <SDI OPT 2 IN> terminal that is selected for input is to be output from the <SDI OPT 1/2 OUT> terminal.
[DISABLE]	Does not output the signal from the <SDI OPT 1/2 OUT> terminal.

Setting [RESOLUTION] in [SLOT IN] (OPT input)

- 1) Select **[DISPLAY OPTION]** from the main menu.

- 2) Press the <ENTER> button.
 - The [DISPLAY OPTION] screen is displayed.
- 3) Press ▲▼ to select [SLOT IN].
- 4) Press the <ENTER> button.
 - The [SLOT IN] screen is displayed.
- 5) Press ▲▼ to select [SDI OPT1] or [SDI OPT2], and press the <ENTER> button.
 - The detailed setting screen for the selected item is displayed.
- 6) Press ▲▼ to select [RESOLUTION], and press the <ENTER> button.
 - The [RESOLUTION] screen is displayed.
- 7) Press ▲▼ to select an item, and press the <ENTER> button.
 - Select [AUTO], [1280x720p], [1920x1080i], [1920x1080p], [1920x1080sF], [2048x1080p], [3840x2160p], or [4096x2160p].

Setting [SDI MAPPING] in [SLOT IN] (OPT input)

- 1) Select [DISPLAY OPTION] from the main menu.
- 2) Press the <ENTER> button.
 - The [DISPLAY OPTION] screen is displayed.
- 3) Press ▲▼ to select [SLOT IN].
- 4) Press the <ENTER> button.
 - The [SLOT IN] screen is displayed.
- 5) Press ▲▼ to select [SDI OPT1] or [SDI OPT2], and press the <ENTER> button.
 - The detailed setting screen for the selected item is displayed.
- 6) Press ▲▼ to select [SDI MAPPING].
- 7) Press ◀▶ to switch the item.
 - The items will switch each time you press the button.

[AUTO]	Automatically selects [TYPE1/LEVEL A] or [TYPE2/LEVEL B].
[TYPE1/LEVEL A]	Fixes the mapping method to Type 1 or Level-A.
[TYPE2/LEVEL B]	Fixes the mapping method to Type 2 or Level-B.

Note

- This function does not operate when the HD-SDI signal is input.

Setting [SYSTEM SELECTOR] in [SLOT IN] (OPT input)

- 1) Select [DISPLAY OPTION] from the main menu.
- 2) Press the <ENTER> button.
 - The [DISPLAY OPTION] screen is displayed.
- 3) Press ▲▼ to select [SLOT IN].
- 4) Press the <ENTER> button.
 - The [SLOT IN] screen is displayed.
- 5) Press ▲▼ to select [SDI OPT1] or [SDI OPT2], and press the <ENTER> button.
 - The detailed setting screen for the selected item is displayed.
- 6) Press ▲▼ to select [SYSTEM SELECTOR].
- 7) Press ◀▶ to switch the item.
 - The items will switch each time you press the button.

Menu navigation

[AUTO]	Automatically selects [RGB], [YP _B P _R 4:4:4], or [YP _B P _R 4:2:2].
[RGB]	Fixes to [RGB].
[YP _B P _R 4:4:4]	Fixes to [YP _B P _R 4:4:4].
[YP _B P _R 4:2:2]	Fixes to [YP _B P _R 4:2:2].

Setting [BIT DEPTH] in [SLOT IN] (OPT input)

- 1) Select [DISPLAY OPTION] from the main menu.
- 2) Press the <ENTER> button.
 - The [DISPLAY OPTION] screen is displayed.
- 3) Press ▲▼ to select [SLOT IN].
- 4) Press the <ENTER> button.
 - The [SLOT IN] screen is displayed.
- 5) Press ▲▼ to select [SDI OPT1] or [SDI OPT2], and press the <ENTER> button.
 - The detailed setting screen for the selected item is displayed.
- 6) Press ▲▼ to select [BIT DEPTH].
- 7) Press ◀▶ to switch the item.
 - The items will switch each time you press the button.

[AUTO]	Automatically selects [12-bit] or [10-bit].
[12-bit]	Fixes to [12-bit].
[10-bit]	Fixes to [10-bit].

Setting [SIGNAL LEVEL] in [SLOT IN] (OPT input)

- 1) Select [DISPLAY OPTION] from the main menu.
- 2) Press the <ENTER> button.
 - The [DISPLAY OPTION] screen is displayed.
- 3) Press ▲▼ to select [SLOT IN].
- 4) Press the <ENTER> button.
 - The [SLOT IN] screen is displayed.
- 5) Press ▲▼ to select [SDI OPT1] or [SDI OPT2], and press the <ENTER> button.
 - The detailed setting screen for the selected item is displayed.
- 6) Press ▲▼ to select [SIGNAL LEVEL].
- 7) Press ◀▶ to switch the item.
 - The items will switch each time you press the button.

[64-940]	Normally use this setting.
[4-1019]	Select this item when gray is displayed as black.

[SECONDARY INPUT]

Set the secondary input switching function that will automatically switch to the specified input when the input signal of projecting image is discontinued.

- 1) Select [PROJECTOR SETUP] from the main menu.
- 2) Press the <ENTER> button.
 - The [PROJECTOR SETUP] screen is displayed.
- 3) Press ▲▼ to select [NO SIGNAL SETTING].

- 4) Press the <ENTER> button.
 - The [NO SIGNAL SETTING] screen is displayed.
- 5) Press ▲▼ to select [SECONDARY INPUT].
- 6) Press the <ENTER> button.
 - The [SECONDARY INPUT] screen is displayed.
- 7) Press ▲▼ to select the input to be specified as the switching destination, and press the <ENTER> button.

[OFF]	Disables the secondary input switching function.
[SDI OPT1 [SLOT1]]*1	Sets the secondary input to SDI OPT1 of the Interface Board.
[SDI OPT2 [SLOT1]]*1	Sets the secondary input to SDI OPT2 of the Interface Board.
[SDI OPT1 [SLOT2]]*2	Sets the secondary input to SDI OPT1 of the Interface Board.
[SDI OPT2 [SLOT2]]*2	Sets the secondary input to SDI OPT2 of the Interface Board.
[SDI OPT1 [SLOT]]*3	Sets the secondary input to SDI OPT1 of the Interface Board.
[SDI OPT2 [SLOT]]*3	Sets the secondary input to SDI OPT2 of the Interface Board.

*1 This is displayed when this Interface Board is installed in <SLOT 1>.

*2 This is displayed when this Interface Board is installed in <SLOT 2>.

*3 This is displayed when this Interface Board is installed in <SLOT>.

[STARTUP INPUT SELECT]

Set the input when the projector is switched on to start projection.

- 1) Select [PROJECTOR SETUP] from the main menu.
- 2) Press the <ENTER> button.
 - The [PROJECTOR SETUP] screen is displayed.
- 3) Press ▲▼ to select [STARTUP INPUT SELECT].
- 4) Press the <ENTER> button.
 - The [STARTUP INPUT SELECT] screen is displayed.
- 5) Press ▲▼◀▶ to select the input, and press the <ENTER> button.

[SDI OPT1 [SLOT1]]*1	Sets the input to SDI OPT1 of the Interface Board.
[SDI OPT2 [SLOT1]]*1	Sets the input to SDI OPT2 of the Interface Board.
[SDI OPT1 [SLOT2]]*2	Sets the input to SDI OPT1 of the Interface Board.
[SDI OPT2 [SLOT2]]*2	Sets the input to SDI OPT2 of the Interface Board.
[SDI OPT1 [SLOT]]*3	Sets the input to SDI OPT1 of the Interface Board.
[SDI OPT2 [SLOT]]*3	Sets the input to SDI OPT2 of the Interface Board.

*1 This is displayed when this Interface Board is installed in <SLOT 1>.

*2 This is displayed when this Interface Board is installed in <SLOT 2>.

*3 This is displayed when this Interface Board is installed in <SLOT>.

[SCHEDULE]

Set the command execution schedule for each day of the week.

Enabling/disabling the schedule function

- 1) Select [PROJECTOR SETUP] from the main menu.
- 2) Press the <ENTER> button.
 - The [PROJECTOR SETUP] screen is displayed.
- 3) Press ▲▼ to select [SCHEDULE].
- 4) Press ◀▶ to switch the item.
 - The items will switch each time you press the button.

[OFF]	Disables the schedule function.
-------	---------------------------------

[ON]	Enables the schedule function. Refer to “How to assign a program” (➔ page 18) or “How to set a program” (➔ page 18) for how to set the schedule.
------	--------------------------------------------------------------------------------------------------------------------------------------------------

How to assign a program

- 1) Select [PROJECTOR SETUP] from the main menu.
- 2) Press the <ENTER> button.
 - The [PROJECTOR SETUP] screen is displayed.
- 3) Press ▲▼ to select [SCHEDULE].
- 4) Press ◀▶ to select [ON], and press the <ENTER> button.
 - The [SCHEDULE] screen is displayed.
- 5) Select and assign a program to each day of week.
 - Press ▲▼ to select the day of week, and press ◀▶ to select a program number.
 - You can set the program from No.1 to No.7. “- -” indicates that the program number has not been set.

How to set a program

Set up to 16 commands to each program.

- 1) Select [PROJECTOR SETUP] from the main menu.
- 2) Press the <ENTER> button.
 - The [PROJECTOR SETUP] screen is displayed.
- 3) Press ▲▼ to select [SCHEDULE].
- 4) Press ◀▶ to select [ON], and press the <ENTER> button.
 - The [SCHEDULE] screen is displayed.
- 5) Press ▲▼ to select [PROGRAM EDIT].
- 6) Press ◀▶ to select a program number, and press the <ENTER> button.
- 7) Press ▲▼ to select a command number, and press the <ENTER> button.
 - You can change the page using ◀▶.
- 8) Press ▲▼◀▶ to select [TIME], and press the <ENTER> button.
 - The projector is in the adjustment mode (the time is blinking).
- 9) Press ◀▶ to select “hour” or “minute”, and press ▲▼ or the number (<0> - <9>) buttons to set a time, and then press the <ENTER> button.
- 10) Press ▲▼◀▶ to select [COMMAND].
- 11) Press the <ENTER> button.
 - The [COMMAND] detailed setting screen is displayed.
- 12) Press ▲▼ to select [INPUT], and press the <ENTER> button.
- 13) Press ▲▼◀▶ to select the input to be set.

[COMMAND]	Detailed settings of [COMMAND]	Description
[INPUT]	[SDI OPT1 [SLOT1]]*1	Switches the input to SDI OPT1 of the Interface Board.
	[SDI OPT2 [SLOT1]]*1	Switches the input to SDI OPT2 of the Interface Board.
	[SDI OPT1 [SLOT2]]*2	Switches the input to SDI OPT1 of the Interface Board.
	[SDI OPT2 [SLOT2]]*2	Switches the input to SDI OPT2 of the Interface Board.
	[SDI OPT1 [SLOT]]*3	Switches the input to SDI OPT1 of the Interface Board.
	[SDI OPT2 [SLOT]]*3	Switches the input to SDI OPT2 of the Interface Board.

*1 This is displayed when this Interface Board is installed in <SLOT 1>.

*2 This is displayed when this Interface Board is installed in <SLOT 2>.

*3 This is displayed when this Interface Board is installed in <SLOT>.

14) Press the <ENTER> button.

- The command is fixed and ● is displayed at the left of the selected command.
- After the command is fixed, press the <MENU> button to close the detailed setting screen.

15) Press ▲▼◀▶ to select [STORE], and press the <ENTER> button.

Note

- To delete a command that has been already set, press the <DEFAULT> button on the remote control while the screen in Step 7) is displayed, or select [DELETE] at the screen in Step 8) and press the <ENTER> button.
- If multiple commands have been set for the same time, they are executed in chronological order starting from the smallest command number.
- The operation is performed with the local time set in the projector.
- If an operation is executed with the remote control or control panel of the projector or with a control command before the command set in [SCHEDULE] is executed, the command set with the schedule function may not be executed.

[REMOTE2 MODE]

Set the <REMOTE 2 IN> terminal.

1) Select [PROJECTOR SETUP] from the main menu.

2) Press the <ENTER> button.

- The [PROJECTOR SETUP] screen is displayed.

3) Press ▲▼ to select [REMOTE2 MODE].

4) Press ◀▶ to switch to [USER].

- The items will switch each time you press the button.

[DEFAULT]	Uses pin assignment of the <REMOTE 2 IN> terminal in standard setting of the projector.
[USER]	Changes the setting of the <REMOTE 2 IN> terminal.

5) Press the <ENTER> button.

- The [REMOTE2 MODE] screen is displayed.

6) Press ▲▼ to select one from [PIN3] to [PIN7], and press ◀▶ to switch the setting.

- The items will switch each time you press the button.

[SDI OPT1 [SLOT1]]*1	Sets the pin to the SDI OPT1 input of the Interface Board.
[SDI OPT2 [SLOT1]]*1	Sets the pin to the SDI OPT2 input of the Interface Board.
[SDI OPT1 [SLOT2]]*2	Sets the pin to the SDI OPT1 input of the Interface Board.
[SDI OPT2 [SLOT2]]*2	Sets the pin to the SDI OPT2 input of the Interface Board.
[SDI OPT1 [SLOT]]*3	Sets the pin to the SDI OPT1 input of the Interface Board.
[SDI OPT2 [SLOT]]*3	Sets the pin to the SDI OPT2 input of the Interface Board.

*1 This is displayed when this Interface Board is installed in <SLOT 1>.

*2 This is displayed when this Interface Board is installed in <SLOT 2>.

*3 This is displayed when this Interface Board is installed in <SLOT>.

[MULTI DISPLAY]

Four images can be displayed simultaneously by dividing the projection screen into four.

The multi-display function setting can be saved to [USER1], [USER2], or [USER3].

1) Select [MULTI DISPLAY] from the main menu.

2) Press the <ENTER> button.

- The [MULTI DISPLAY] screen is displayed.

3) Press ▲▼ to select [MULTI DISPLAY MODE].

4) Press the <ENTER> button.

- The [MULTI DISPLAY MODE] screen is displayed.

5) Press ▲▼ to select a mode from [USER1], [USER2], or [USER3].

Menu navigation

[OFF]	Does not use the multi-display function.
[USER1]	Displays the images in four-screen display with the structure of the input terminals to be set in Step 8).
[USER2]	
[USER3]	

- 6) Press the <ENTER> button.
- 7) Press ▲▼ to select [UPPER LEFT WINDOW], [UPPER RIGHT WINDOW], [LOWER LEFT WINDOW], or [LOWER RIGHT WINDOW], and press the <ENTER> button.
 - The [UPPER LEFT WINDOW] screen, the [UPPER RIGHT WINDOW] screen, the [LOWER LEFT WINDOW] screen, or the [LOWER RIGHT WINDOW] screen is displayed.
- 8) Press ▲▼ to select the input terminal to be displayed in the window, and press the <ENTER> button.

[SDI OPT1 [SLOT1]]*1	Sets the input terminal to the SDI OPT1 input of the Interface Board.
[SDI OPT2 [SLOT1]]*1	Sets the input terminal to the SDI OPT2 input of the Interface Board.
[SDI OPT1 [SLOT2]]*2	Sets the input terminal to the SDI OPT1 input of the Interface Board.
[SDI OPT2 [SLOT2]]*2	Sets the input terminal to the SDI OPT2 input of the Interface Board.
[SDI OPT1 [SLOT]]*3	Sets the input terminal to the SDI OPT1 input of the Interface Board.
[SDI OPT2 [SLOT]]*3	Sets the input terminal to the SDI OPT2 input of the Interface Board.

*1 This is displayed when this Interface Board is installed in <SLOT 1>.

*2 This is displayed when this Interface Board is installed in <SLOT 2>.

*3 This is displayed when this Interface Board is installed in <SLOT>.

- 9) Press ▲▼ to select [FRAME LOCK].
- 10) Press ◀▶ to switch the item.
 - The items will switch each time you press the button.

[UPPER LEFT WINDOW]	Sets the frame lock for the input signal set to the upper left window.
[UPPER RIGHT WINDOW]	Sets the frame lock for the input signal set to the upper right window.
[LOWER LEFT WINDOW]	Sets the frame lock for the input signal set to the lower left window.
[LOWER RIGHT WINDOW]	Sets the frame lock for the input signal set to the lower right window.

Note

- The image currently displayed in the four dividing screen is not projected correctly when the following video signal is input.
 - Video signal with resolution exceeding 1 920 x 1 200 dots
 - Video signal with dot clock frequency exceeding 162 MHz
 - 6G-SDI signal, 12G-SDI signal
- Two input terminals of this Interface Board cannot be selected simultaneously as the input to be displayed in the four-screen display window. Only one of the input terminals can be selected.
- The appearance may vary for each when an image from one input terminal is displayed on multiple screens.
- The setting value against the input signal set at the upper left screen is applied to all screens as the image adjustment value such as the [PICTURE] menu → [PICTURE MODE], [GAMMA], or [COLOR TEMPERATURE].
- The movement of the displayed image becomes discontinuous when [FRAME LOCK] is set for the still image signal.
- The movement of the displayed image may become discontinuous for the images where [FRAME LOCK] is not set.
- The setting in the [ADVANCED MENU] menu → [FRAME RESPONSE] is disabled while in the four-screen display mode.
- The setting in the [ADVANCED MENU] menu → [FRAME CREATION] is disabled and fixed to [OFF] while in the four-screen display mode.
- The [ADVANCED MENU] menu → [QUAD PIXEL DRIVE] is fixed to [ON] while in the four-screen display mode.

[CONTROL DEVICE SETUP]

Enable/disable the button operations on the control panel and the remote control of the projector.

- 1) Select [SECURITY] from the main menu.
- 2) Press the <ENTER> button.
 - The [SECURITY] screen is displayed.
Enter the security password set on the projector, and press the <ENTER> button.
- 3) Press ▲▼ to select [CONTROL DEVICE SETUP].
- 4) Press the <ENTER> button.
 - The [CONTROL DEVICE SETUP] screen is displayed.
- 5) Press ▲▼ to select [CONTROL PANEL] or [REMOTE CONTROL].

Menu navigation

[CONTROL PANEL]	Sets the limitation on the control from the control panel of the projector.
[REMOTE CONTROL]	Sets the limitation on the control from the remote control of the projector.

6) Press the <ENTER> button.

- The [CONTROL PANEL] screen or the [REMOTE CONTROL] screen is displayed.

7) Press ▲▼ to select [CONTROL PANEL] or [REMOTE CONTROL].

8) Press ◀▶ to switch to [USER].

- The limitation of the control from the control panel or the remote control of the projector can be set.

[ENABLE]	Enables all button operations.
[DISABLE]	Disables all button operations.
[USER]	Operation of all buttons can be enabled/disabled separately.

9) Press ▲▼ to select [INPUT SELECT BUTTON], and press the <ENTER> button.

- The [INPUT SELECT BUTTON] screen is displayed.

10) Press ▲▼ to select [SLOT1 BUTTON], [SLOT2 BUTTON], or [SLOT BUTTON].

11) Press ◀▶ to switch the item.

- The items will switch each time you press the button.

[TOGGLE]	Switches the input of the Interface Board installed in the corresponding slot in turn when the button is operated.
[SDI OPT1 [SLOT1]]* ¹	Fixes to selection operation of the SDI OPT1 input of the Interface Board.
[SDI OPT2 [SLOT1]]* ¹	Fixes to selection operation of the SDI OPT2 input of the Interface Board.
[SDI OPT1 [SLOT2]]* ²	Fixes to selection operation of the SDI OPT1 input of the Interface Board.
[SDI OPT2 [SLOT2]]* ²	Fixes to selection operation of the SDI OPT2 input of the Interface Board.
[SDI OPT1 [SLOT]]* ³	Fixes to selection operation of the SDI OPT1 input of the Interface Board.
[SDI OPT2 [SLOT]]* ³	Fixes to selection operation of the SDI OPT2 input of the Interface Board.
[DISABLE]	Disables button operations.

*1 This is displayed when [SLOT1 BUTTON] is set and this Interface Board is installed in <SLOT 1>.

*2 This is displayed when [SLOT2 BUTTON] is set and this Interface Board is installed in <SLOT 2>.

*3 This is displayed when [SLOT BUTTON] is set and this Interface Board is installed in <SLOT>.

12) Press the <MENU> button.

- Returns to the [CONTROL PANEL] screen or the [REMOTE CONTROL] screen.

13) Press ▲▼ to select [APPLY], and press the <ENTER> button.

- The confirmation screen is displayed.

14) Press ◀▶ to select [OK], and press the <ENTER> button.

Note

- When a button operation is performed on the device set to [DISABLE], the [CONTROL DEVICE PASSWORD] screen is displayed. Enter the control device password.
- The [CONTROL DEVICE PASSWORD] screen will disappear when there is no operation for approximately 10 seconds.
- If the operations of both [CONTROL PANEL] and [REMOTE CONTROL] are set to [DISABLE], the projector cannot be turned off (cannot enter standby).
- When the setting has completed, the menu screen will disappear. To operate continuously, press the <MENU> button to display the main menu.
- Even when you set button operations on the remote control disabled, operations of the <ID SET> and <ID ALL> buttons on the remote control are kept enabled.

Appendix

Troubleshooting

Review the following points.

Problems	Points to be checked
The OPT input image is not displayed.	<ul style="list-style-type: none"> • Is the SFP module installed correctly? • Is the optical fiber cable connected correctly? • Is a signal not supported by this Interface Board or the SFP module input? • Is there dust or dirt on the connector of the SFP module or the optical fiber cable?
Cannot switch to the input of the Interface Board.	<ul style="list-style-type: none"> • Is the Interface Board correctly installed in the slot?

Attention

- If problems persist even after checking the preceding points, consult your dealer.

Control command

The following table describes a command to switch to the input of this Interface Board installed on the projector from a computer.

Command	Details	Parameter	Remark
IIS	Switching the input signal	AU1,OP1*1 AU1,OP2*1 AU2,OP1*2 AU2,OP2*2	SDI OPT1 [SLOT1], SDI OPT1 [SLOT] SDI OPT2 [SLOT1], SDI OPT2 [SLOT] SDI OPT1 [SLOT2] SDI OPT2 [SLOT2]

*1 This can be used when this Interface Board is installed in <SLOT 1> or <SLOT>.

*2 This can be used when this Interface Board is installed in <SLOT 2>.

List of compatible signals

The following table describes the video signals supported by this Interface Board.

This Interface Board supports only the single link SDI signal. The dual link SDI signal and the quad link SDI signals are not supported. Also, the image may not display correctly depending on the specification of the SFP module in use. Install the SFP module appropriate for the video signal to be input.

- The content of the 4K division column is as follows.
 - IL: Interleave (transmission format of 2-Sample Interleave Division)

Signal name (SIGNAL FORMAT)	Resolution (Dots)	Scanning freq.		Dot clock freq. (MHz)	4K division	Format	Color format	Sampling
		Horizontal (kHz)	Vertical (Hz)					
720/60p	1 280 x 720	45.0	60.0*1	74.3	—	HD-SDI	YP _B P _R	4:2:2 10bit
720/50p	1 280 x 720	37.5	50.0	74.3	—	HD-SDI	YP _B P _R	4:2:2 10bit
1080/60i	1 920 x 1 080i	33.8	60.0*1	74.3	—	HD-SDI	YP _B P _R	4:2:2 10bit
	1 920 x 1 080i	33.8	60.0*1	74.3	—	3G-SDI Level-A	RGB	4:4:4 10bit
	1 920 x 1 080i	33.8	60.0*1	74.3	—	3G-SDI Level-B	RGB	4:4:4 10bit
	1 920 x 1 080i	33.8	60.0*1	74.3	—	3G-SDI Level-A	RGB	4:4:4 12bit
	1 920 x 1 080i	33.8	60.0*1	74.3	—	3G-SDI Level-B	RGB	4:4:4 12bit
1080/50i	1 920 x 1 080i	28.1	50.0	74.3	—	HD-SDI	YP _B P _R	4:2:2 10bit
	1 920 x 1 080i	28.1	50.0	74.3	—	3G-SDI Level-A	RGB	4:4:4 10bit
	1 920 x 1 080i	28.1	50.0	74.3	—	3G-SDI Level-B	RGB	4:4:4 10bit
	1 920 x 1 080i	28.1	50.0	74.3	—	3G-SDI Level-A	RGB	4:4:4 12bit
	1 920 x 1 080i	28.1	50.0	74.3	—	3G-SDI Level-B	RGB	4:4:4 12bit
1080/24p	1 920 x 1 080	27.0	24.0*1	74.3	—	HD-SDI	YP _B P _R	4:2:2 10bit
	1 920 x 1 080	27.0	24.0*1	74.3	—	3G-SDI Level-A	RGB	4:4:4 10bit
	1 920 x 1 080	27.0	24.0*1	74.3	—	3G-SDI Level-B	RGB	4:4:4 10bit
	1 920 x 1 080	27.0	24.0*1	74.3	—	3G-SDI Level-A	RGB	4:4:4 12bit
	1 920 x 1 080	27.0	24.0*1	74.3	—	3G-SDI Level-B	RGB	4:4:4 12bit
1080/24sF	1 920 x 1 080i	27.0	48.0*1	74.3	—	HD-SDI	YP _B P _R	4:2:2 10bit
	1 920 x 1 080i	27.0	48.0*1	74.3	—	3G-SDI Level-A	RGB	4:4:4 10bit
	1 920 x 1 080i	27.0	48.0*1	74.3	—	3G-SDI Level-B	RGB	4:4:4 10bit
	1 920 x 1 080i	27.0	48.0*1	74.3	—	3G-SDI Level-A	RGB	4:4:4 12bit
	1 920 x 1 080i	27.0	48.0*1	74.3	—	3G-SDI Level-B	RGB	4:4:4 12bit
1080/25p	1 920 x 1 080	28.1	25.0	74.3	—	HD-SDI	YP _B P _R	4:2:2 10bit
	1 920 x 1 080	28.1	25.0	74.3	—	3G-SDI Level-A	RGB	4:4:4 10bit
	1 920 x 1 080	28.1	25.0	74.3	—	3G-SDI Level-B	RGB	4:4:4 10bit
	1 920 x 1 080	28.1	25.0	74.3	—	3G-SDI Level-A	RGB	4:4:4 12bit
	1 920 x 1 080	28.1	25.0	74.3	—	3G-SDI Level-B	RGB	4:4:4 12bit
1080/30p	1 920 x 1 080	33.8	30.0*1	74.3	—	HD-SDI	YP _B P _R	4:2:2 10bit
	1 920 x 1 080	33.8	30.0*1	74.3	—	3G-SDI Level-A	RGB	4:4:4 10bit
	1 920 x 1 080	33.8	30.0*1	74.3	—	3G-SDI Level-B	RGB	4:4:4 10bit
	1 920 x 1 080	33.8	30.0*1	74.3	—	3G-SDI Level-A	RGB	4:4:4 12bit
	1 920 x 1 080	33.8	30.0*1	74.3	—	3G-SDI Level-B	RGB	4:4:4 12bit
1080/60p	1 920 x 1 080	67.5	60.0*1	148.5	—	3G-SDI Level-A	YP _B P _R	4:2:2 10bit
	1 920 x 1 080	67.5	60.0*1	148.5	—	3G-SDI Level-B	YP _B P _R	4:2:2 10bit
	1 920 x 1 080	67.5	60.0*1	148.5	—	6G-SDI Type 1	YP _B P _R	4:4:4 10bit
	1 920 x 1 080	67.5	60.0*1	148.5	—	6G-SDI Type 1	YP _B P _R	4:4:4 12bit
	1 920 x 1 080	67.5	60.0*1	148.5	—	6G-SDI Type 1	RGB	4:4:4 10bit
	1 920 x 1 080	67.5	60.0*1	148.5	—	6G-SDI Type 1	RGB	4:4:4 12bit
1080/50p	1 920 x 1 080	56.3	50.0	148.5	—	3G-SDI Level-A	YP _B P _R	4:2:2 10bit
	1 920 x 1 080	56.3	50.0	148.5	—	3G-SDI Level-B	YP _B P _R	4:2:2 10bit
	1 920 x 1 080	56.3	50.0	148.5	—	6G-SDI Type 1	YP _B P _R	4:4:4 10bit
	1 920 x 1 080	56.3	50.0	148.5	—	6G-SDI Type 1	YP _B P _R	4:4:4 12bit
	1 920 x 1 080	56.3	50.0	148.5	—	6G-SDI Type 1	RGB	4:4:4 10bit
	1 920 x 1 080	56.3	50.0	148.5	—	6G-SDI Type 1	RGB	4:4:4 12bit
2K/24p	2 048 x 1 080	27.0	24.0*1	74.3	—	3G-SDI Level-A	RGB	4:4:4 10bit
	2 048 x 1 080	27.0	24.0*1	74.3	—	3G-SDI Level-B	RGB	4:4:4 10bit
	2 048 x 1 080	27.0	24.0*1	74.3	—	3G-SDI Level-A	RGB	4:4:4 12bit
	2 048 x 1 080	27.0	24.0*1	74.3	—	3G-SDI Level-B	RGB	4:4:4 12bit

Appendix

Signal name (SIGNAL FORMAT)	Resolution (Dots)	Scanning freq.		Dot clock freq. (MHz)	4K division	Format	Color format	Sampling
		Horizontal (kHz)	Vertical (Hz)					
2K/25p	2 048 x 1 080	28.1	25.0	74.3	—	3G-SDI Level-A	RGB	4:4:4 10bit
	2 048 x 1 080	28.1	25.0	74.3	—	3G-SDI Level-B	RGB	4:4:4 10bit
	2 048 x 1 080	28.1	25.0	74.3	—	3G-SDI Level-A	RGB	4:4:4 12bit
	2 048 x 1 080	28.1	25.0	74.3	—	3G-SDI Level-B	RGB	4:4:4 12bit
2K/30p	2 048 x 1 080	33.8	30.0*1	74.3	—	3G-SDI Level-A	RGB	4:4:4 10bit
	2 048 x 1 080	33.8	30.0*1	74.3	—	3G-SDI Level-B	RGB	4:4:4 10bit
	2 048 x 1 080	33.8	30.0*1	74.3	—	3G-SDI Level-A	RGB	4:4:4 12bit
	2 048 x 1 080	33.8	30.0*1	74.3	—	3G-SDI Level-B	RGB	4:4:4 12bit
2K/48p	2 048 x 1 080	54.0	48.0*1	148.5	—	3G-SDI Level-A	YP _B P _R	4:2:2 10bit
	2 048 x 1 080	54.0	48.0*1	148.5	—	3G-SDI Level-B	YP _B P _R	4:2:2 10bit
2K/60p	2 048 x 1 080	67.5	60.0*1	148.5	—	3G-SDI Level-A	YP _B P _R	4:2:2 10bit
	2 048 x 1 080	67.5	60.0*1	148.5	—	3G-SDI Level-B	YP _B P _R	4:2:2 10bit
	2 048 x 1 080	67.5	60.0*1	148.5	—	6G-SDI Type 1	YP _B P _R	4:4:4 10bit
	2 048 x 1 080	67.5	60.0*1	148.5	—	6G-SDI Type 1	YP _B P _R	4:4:4 12bit
	2 048 x 1 080	67.5	60.0*1	148.5	—	6G-SDI Type 1	RGB	4:4:4 10bit
	2 048 x 1 080	67.5	60.0*1	148.5	—	6G-SDI Type 1	RGB	4:4:4 12bit
2K/50p	2 048 x 1 080	56.3	50.0	148.5	—	3G-SDI Level-A	YP _B P _R	4:2:2 10bit
	2 048 x 1 080	56.3	50.0	148.5	—	3G-SDI Level-B	YP _B P _R	4:2:2 10bit
	2 048 x 1 080	56.3	50.0	148.5	—	6G-SDI Type 1	YP _B P _R	4:4:4 10bit
	2 048 x 1 080	56.3	50.0	148.5	—	6G-SDI Type 1	YP _B P _R	4:4:4 12bit
	2 048 x 1 080	56.3	50.0	148.5	—	6G-SDI Type 1	RGB	4:4:4 10bit
	2 048 x 1 080	56.3	50.0	148.5	—	6G-SDI Type 1	RGB	4:4:4 12bit
3840 x 2160/24p	3 840 x 2 160	54.0	24.0*1	297.0	IL	6G-SDI Type 2	YP _B P _R	4:2:2 10bit
	3 840 x 2 160	54.0	24.0*1	297.0	IL	12G-SDI Type 1	YP _B P _R	4:2:2 12bit
	3 840 x 2 160	54.0	24.0*1	297.0	IL	12G-SDI Type 1	YP _B P _R	4:4:4 10bit
	3 840 x 2 160	54.0	24.0*1	297.0	IL	12G-SDI Type 1	YP _B P _R	4:4:4 12bit
	3 840 x 2 160	54.0	24.0*1	297.0	IL	12G-SDI Type 1	RGB	4:4:4 10bit
	3 840 x 2 160	54.0	24.0*1	297.0	IL	12G-SDI Type 1	RGB	4:4:4 12bit
3840 x 2160/25p	3 840 x 2 160	56.3	25.0	297.0	IL	6G-SDI Type 2	YP _B P _R	4:2:2 10bit
	3 840 x 2 160	56.3	25.0	297.0	IL	12G-SDI Type 1	YP _B P _R	4:2:2 12bit
	3 840 x 2 160	56.3	25.0	297.0	IL	12G-SDI Type 1	YP _B P _R	4:4:4 10bit
	3 840 x 2 160	56.3	25.0	297.0	IL	12G-SDI Type 1	YP _B P _R	4:4:4 12bit
	3 840 x 2 160	56.3	25.0	297.0	IL	12G-SDI Type 1	RGB	4:4:4 10bit
	3 840 x 2 160	56.3	25.0	297.0	IL	12G-SDI Type 1	RGB	4:4:4 12bit
3840 x 2160/30p	3 840 x 2 160	67.5	30.0*1	297.0	IL	6G-SDI Type 2	YP _B P _R	4:2:2 10bit
	3 840 x 2 160	67.5	30.0*1	297.0	IL	12G-SDI Type 1	YP _B P _R	4:2:2 12bit
	3 840 x 2 160	67.5	30.0*1	297.0	IL	12G-SDI Type 1	YP _B P _R	4:4:4 10bit
	3 840 x 2 160	67.5	30.0*1	297.0	IL	12G-SDI Type 1	YP _B P _R	4:4:4 12bit
	3 840 x 2 160	67.5	30.0*1	297.0	IL	12G-SDI Type 1	RGB	4:4:4 10bit
	3 840 x 2 160	67.5	30.0*1	297.0	IL	12G-SDI Type 1	RGB	4:4:4 12bit
3840 x 2160/60p	3 840 x 2 160	135.0	60.0*1	594.0	IL	12G-SDI Type 1	YP _B P _R	4:2:2 10bit
3840 x 2160/50p	3 840 x 2 160	112.5	50.0	594.0	IL	12G-SDI Type 1	YP _B P _R	4:2:2 10bit
4096 x 2160/24p	4 096 x 2 160	54.0	24.0*1	297.0	IL	6G-SDI Type 2	YP _B P _R	4:2:2 10bit
	4 096 x 2 160	54.0	24.0*1	297.0	IL	12G-SDI Type 1	YP _B P _R	4:2:2 12bit
	4 096 x 2 160	54.0	24.0*1	297.0	IL	12G-SDI Type 1	YP _B P _R	4:4:4 10bit
	4 096 x 2 160	54.0	24.0*1	297.0	IL	12G-SDI Type 1	YP _B P _R	4:4:4 12bit
	4 096 x 2 160	54.0	24.0*1	297.0	IL	12G-SDI Type 1	RGB	4:4:4 10bit
	4 096 x 2 160	54.0	24.0*1	297.0	IL	12G-SDI Type 1	RGB	4:4:4 12bit
4096 x 2160/25p	4 096 x 2 160	56.3	25.0	297.0	IL	6G-SDI Type 2	YP _B P _R	4:2:2 10bit
	4 096 x 2 160	56.3	25.0	297.0	IL	12G-SDI Type 1	YP _B P _R	4:2:2 12bit
	4 096 x 2 160	56.3	25.0	297.0	IL	12G-SDI Type 1	YP _B P _R	4:4:4 10bit
	4 096 x 2 160	56.3	25.0	297.0	IL	12G-SDI Type 1	YP _B P _R	4:4:4 12bit
	4 096 x 2 160	56.3	25.0	297.0	IL	12G-SDI Type 1	RGB	4:4:4 10bit
	4 096 x 2 160	56.3	25.0	297.0	IL	12G-SDI Type 1	RGB	4:4:4 12bit

Appendix

Signal name (SIGNAL FORMAT)	Resolution (Dots)	Scanning freq.		Dot clock freq. (MHz)	4K division	Format	Color format	Sampling
		Horizontal (kHz)	Vertical (Hz)					
4096 x 2160/30p	4 096 x 2 160	67.5	30.0*1	297.0	IL	6G-SDI Type 2	YP _B P _R	4:2:2 10bit
	4 096 x 2 160	67.5	30.0*1	297.0	IL	12G-SDI Type 1	YP _B P _R	4:2:2 12bit
	4 096 x 2 160	67.5	30.0*1	297.0	IL	12G-SDI Type 1	YP _B P _R	4:4:4 10bit
	4 096 x 2 160	67.5	30.0*1	297.0	IL	12G-SDI Type 1	YP _B P _R	4:4:4 12bit
	4 096 x 2 160	67.5	30.0*1	297.0	IL	12G-SDI Type 1	RGB	4:4:4 10bit
	4 096 x 2 160	67.5	30.0*1	297.0	IL	12G-SDI Type 1	RGB	4:4:4 12bit
4096 x 2160/60p	4 096 x 2 160	135.0	60.0*1	594.0	IL	12G-SDI Type 1	YP _B P _R	4:2:2 10bit
4096 x 2160/50p	4 096 x 2 160	112.5	50.0	594.0	IL	12G-SDI Type 1	YP _B P _R	4:2:2 10bit

*1 The signal with 1/1.001x vertical scanning frequency is also supported.

Specifications

Compatible slot		SLOT NX specification	
Connecting terminals		Two SFP ports MSA compliant	
Compatible signal	Input	Single link HD-SDI signal	SMPTE ST 292 compliant
		Single link 3G-SDI signal	SMPTE ST 424, 425-2 compliant
		Single link 6G-SDI signal	SMPTE ST 2081-1, 2081-10 compliant
		Single link 12G-SDI signal	SMPTE ST 2082-1, 2082-10 compliant
	Output	The signal input to the <SDI OPT 1 IN> terminal or the <SDI OPT 2 IN> terminal is output from the <SDI OPT 1/2 OUT> terminal (active through output).	
Dimensions	Width	151 mm (5-15/16")	
	Height	38.5 mm (1-17/32")	
	Depth	142 mm (5-19/32")	
Weight		360 g (12.7 ozs.)	

Note

- "SLOT NX" is a name of the slot unique to Panasonic Projector & Display Corporation supporting the signal input for the 4K image.
- For the video signals supported by this Interface Board, refer to "List of compatible signals" (▶ page 23).
The video signal that the projector can actually display differs depending on the SFP module installed in the SFP port.
- Prepare the commercially available SFP module and the optical fiber cable required for connection according to the usage, video signal to be input, specification of the external device to be connected, etc.

■ Indication of the manufacturer and the importer with EU Directive requirements

<p>English</p>	<p>Manufactured by: Panasonic Projector & Display Corporation 2-15 Matsuba-cho, Kadoma City, Osaka 571-8503, Japan Importer: Panasonic Connect Europe GmbH Hagenauer Strasse 43, 65203 Wiesbaden, Germany Authorized Representative in EU: Panasonic Connect Europe GmbH Panasonic Testing Centre Winsbergring 15, 22525 Hamburg, Germany</p>
<p>Български</p>	<p>Производител: Panasonic Projector & Display Corporation 2-15 Matsuba-cho, Kadoma City, Osaka 571-8503, Япония Вносител: Panasonic Connect Europe GmbH Hagenauer Strasse 43, 65203 Wiesbaden, Германия Упълномощен представител в ЕС: Panasonic Connect Europe GmbH Panasonic Testing Centre Winsbergring 15, 22525 Hamburg, Германия</p>
<p>Čeština</p>	<p>Vyrobil: Panasonic Projector & Display Corporation 2-15 Matsuba-cho, Kadoma City, Osaka 571-8503, Japonsko Dovozce: Panasonic Connect Europe GmbH Hagenauer Strasse 43, 65203 Wiesbaden, Německo Oprávněný zástupce v EU: Panasonic Connect Europe GmbH Panasonic Testing Centre Winsbergring 15, 22525 Hamburg, Německo</p>
<p>Српски</p>	<p>Произведен од: Panasonic Projector & Display Corporation 2-15 Matsuba-cho, Kadoma City, Osaka 571-8503, Јапан Увозник: Panasonic Connect Europe GmbH Hagenauer Strasse 43, 65203 Wiesbaden, Немачка Овлашћени представник у ЕУ: Panasonic Connect Europe GmbH Panasonic Testing Centre Winsbergring 15, 22525 Hamburg, Немачка</p>
<p>Dansk</p>	<p>Fremstillet af: Panasonic Projector & Display Corporation 2-15 Matsuba-cho, Kadoma City, Osaka 571-8503, Japan Importør: Panasonic Connect Europe GmbH Hagenauer Strasse 43, 65203 Wiesbaden, Tyskland Autoriseret repræsentant i EU: Panasonic Connect Europe GmbH Panasonic Testing Centre Winsbergring 15, 22525 Hamburg, Tyskland</p>
<p>Deutsch</p>	<p>Hergestellt von: Panasonic Projector & Display Corporation 2-15 Matsuba-cho, Kadoma City, Osaka 571-8503, Japan Importeur: Panasonic Connect Europe GmbH Hagenauer Strasse 43, 65203 Wiesbaden, Deutschland Vertretungsberechtigter in der EU: Panasonic Connect Europe GmbH Panasonic Testing Centre Winsbergring 15, 22525 Hamburg, Deutschland</p>
<p>Eesti</p>	<p>Tootja: Panasonic Projector & Display Corporation 2-15 Matsuba-cho, Kadoma City, Osaka 571-8503, Jaapan Maaletooja: Panasonic Connect Europe GmbH Hagenauer Strasse 43, 65203 Wiesbaden, Saksamaa Volitatud esindaja ELis: Panasonic Connect Europe GmbH Panasonic Testing Centre Winsbergring 15, 22525 Hamburg, Saksamaa</p>

Ελληνικά	<p>Κατασκευάστηκε από: Panasonic Projector & Display Corporation 2-15 Matsuba-cho, Kadoma City, Osaka 571-8503, Ιαπωνία</p> <p>Εισαγωγέας: Panasonic Connect Europe GmbH Hagenauer Strasse 43, 65203 Wiesbaden, Γερμανία</p> <p>Εξουσιοδοτημένος αντιπρόσωπος στην ΕΕ: Panasonic Connect Europe GmbH Panasonic Testing Centre Winsbergring 15, 22525 Hamburg, Γερμανία</p>
Español	<p>Fabricado por: Panasonic Projector & Display Corporation 2-15 Matsuba-cho, Kadoma City, Osaka 571-8503, Japón</p> <p>Importador: Panasonic Connect Europe GmbH Hagenauer Strasse 43, 65203 Wiesbaden, Alemania</p> <p>Representante Autorizado para la UE: Panasonic Connect Europe GmbH Panasonic Testing Centre Winsbergring 15, 22525 Hamburgo, Alemania</p>
Français	<p>Fabriqué par : Panasonic Projector & Display Corporation 2-15 Matsuba-cho, Kadoma City, Osaka 571-8503, Japon</p> <p>Importateur : Panasonic Connect Europe GmbH Hagenauer Strasse 43, 65203 Wiesbaden, Allemagne</p> <p>Représentant autorisé dans l'UE : Panasonic Connect Europe GmbH Panasonic Testing Centre Winsbergring 15, 22525 Hambourg, Allemagne</p>
Gaeilge	<p>Arna dhéanamh ag : Panasonic Projector & Display Corporation 2-15 Matsuba-cho, Kadoma City, Osaka 571-8503, An tSeapáin</p> <p>Allmhaireoir : Panasonic Connect Europe GmbH Hagenauer Strasse 43, 65203 Wiesbaden, An Ghearmáin</p> <p>Ionadaí Údaraithe san AE : Panasonic Connect Europe GmbH Panasonic Testing Centre Winsbergring 15, 22525 Hamburg, An Ghearmáin</p>
Hrvatski	<p>Proizvodi: Panasonic Projector & Display Corporation 2-15 Matsuba-cho, Kadoma City, Osaka 571-8503, Japan</p> <p>Uvoznik: Panasonic Connect Europe GmbH Hagenauer Strasse 43, 65203 Wiesbaden, Njemačka</p> <p>Ovlašteni zastupnik u EU-u: Panasonic Connect Europe GmbH Panasonic Testing Centre Winsbergring 15, 22525 Hamburg, Njemačka</p>
Íslenskur	<p>Framleitt af: Panasonic Projector & Display Corporation 2-15 Matsuba-cho, Kadoma City, Osaka 571-8503, Japan</p> <p>Innflytjandi: Panasonic Connect Europe GmbH Hagenauer Strasse 43, 65203 Wiesbaden, Þýskalandi</p> <p>Viðurkenndur fulltrúi í ESB: Panasonic Connect Europe GmbH Panasonic Testing Centre Winsbergring 15, 22525 Hamburg, Þýskalandi</p>
Italiano	<p>Fabbricato da: Panasonic Projector & Display Corporation 2-15 Matsuba-cho, Kadoma City, Osaka 571-8503, Giappone</p> <p>Importatore: Panasonic Connect Europe GmbH Hagenauer Strasse 43, 65203 Wiesbaden, Germania</p> <p>Rappresentante autorizzato nell'UE: Panasonic Connect Europe GmbH Panasonic Testing Centre Winsbergring 15, 22525 Amburgo, Germania</p>

Latviešu	<p>Ražotājs: Panasonic Projector & Display Corporation 2-15 Matsuba-cho, Kadoma City, Osaka 571-8503, Japāna</p> <p>Importētājs: Panasonic Connect Europe GmbH Hagenauer Strasse 43, 65203 Wiesbaden, Vācija</p> <p>Oficiālais pārstāvis ES: Panasonic Connect Europe GmbH Panasonic Testing Centre Winsbergring 15, 22525 Hamburg, Vācija</p>
Lietuvių	<p>Gamintojas: Panasonic Projector & Display Corporation 2-15 Matsuba-cho, Kadoma City, Osaka 571-8503, Japonija</p> <p>Importuotojas: Panasonic Connect Europe GmbH Hagenauer Strasse 43, 65203 Wiesbaden, Vokietija</p> <p>Igaliotasis atstovas ES: Panasonic Connect Europe GmbH Panasonic Testing Centre Winsbergring 15, 22525 Hamburgas, Vokietija</p>
Magyar	<p>Gyártotta: Panasonic Projector & Display Corporation 2-15 Matsuba-cho, Kadoma City, Osaka 571-8503, Japán</p> <p>Importőr: Panasonic Connect Europe GmbH Hagenauer Strasse 43, 65203 Wiesbaden, Németország</p> <p>Hivatalos képviselő az EU-ban: Panasonic Connect Europe GmbH Panasonic Testing Centre Winsbergring 15, 22525 Hamburg, Németország</p>
Malti	<p>Manifatturat minn: Panasonic Projector & Display Corporation 2-15 Matsuba-cho, Kadoma City, Osaka 571-8503, il-Ġappun</p> <p>Importatur: Panasonic Connect Europe GmbH Hagenauer Strasse 43, 65203 Wiesbaden, il-Ġermanja</p> <p>Rappreżentant Awtorizzat fl-UE: Panasonic Connect Europe GmbH Panasonic Testing Centre Winsbergring 15, 22525 Hamburg, il-Ġermanja</p>
Nederlands	<p>Geproduceerd door: Panasonic Projector & Display Corporation 2-15 Matsuba-cho, Kadoma City, Osaka 571-8503, Japan</p> <p>Importeur: Panasonic Connect Europe GmbH Hagenauer Strasse 43, 65203 Wiesbaden, Duitsland</p> <p>Bevoegde vertegenwoordiger in de EU: Panasonic Connect Europe GmbH Panasonic Testing Centre Winsbergring 15, 22525 Hamburg, Duitsland</p>
Norsk	<p>Produsert av: Panasonic Projector & Display Corporation 2-15 Matsuba-cho, Kadoma City, Osaka 571-8503, Japan</p> <p>Importør: Panasonic Connect Europe GmbH Hagenauer Strasse 43, 65203 Wiesbaden, Tyskland</p> <p>Autorisert representant i EU: Panasonic Connect Europe GmbH Panasonic Testing Centre Winsbergring 15, 22525 Hamburg, Tyskland</p>
Polski	<p>Wyprodukowano przez: Panasonic Projector & Display Corporation 2-15 Matsuba-cho, Kadoma City, Osaka 571-8503, Japonia</p> <p>Importer: Panasonic Connect Europe GmbH Hagenauer Strasse 43, 65203 Wiesbaden, Niemcy</p> <p>Upoważniony przedstawiciel w UE: Panasonic Connect Europe GmbH Panasonic Testing Centre Winsbergring 15, 22525 Hamburg, Niemcy</p>

Português	<p>Fabricado por: Panasonic Projector & Display Corporation 2-15 Matsuba-cho, Kadoma City, Osaka 571-8503, Japão</p> <p>Importador: Panasonic Connect Europe GmbH Hagenauer Strasse 43, 65203 Wiesbaden, Alemanha</p> <p>Representante Autorizado na UE: Panasonic Connect Europe GmbH Panasonic Testing Centre Winsbergring 15, 22525 Hamburgo, Alemanha</p>
Română	<p>Fabricat de: Panasonic Projector & Display Corporation 2-15 Matsuba-cho, Kadoma City, Osaka 571-8503, Japonia</p> <p>Importator: Panasonic Connect Europe GmbH Hagenauer Strasse 43, 65203 Wiesbaden, Germania</p> <p>Reprezentant autorizat în UE: Panasonic Connect Europe GmbH Panasonic Testing Centre Winsbergring 15, 22525 Hamburg, Germania</p>
Slovenčina	<p>Výrobca: Panasonic Projector & Display Corporation 2-15 Matsuba-cho, Kadoma City, Osaka 571-8503, Japonsko</p> <p>Dovozca: Panasonic Connect Europe GmbH Hagenauer Strasse 43, 65203 Wiesbaden, Nemecko</p> <p>Autorizovaný zástupca v EÚ: Panasonic Connect Europe GmbH Panasonic Testing Centre Winsbergring 15, 22525 Hamburg, Nemecko</p>
Slovenščina	<p>Proizvajaja: Panasonic Projector & Display Corporation 2-15 Matsuba-cho, Kadoma City, Osaka 571-8503, Japonska</p> <p>Uvoznik: Panasonic Connect Europe GmbH Hagenauer Strasse 43, 65203 Wiesbaden, Nemčija</p> <p>Pooblaščenji zastopnik v EU: Panasonic Connect Europe GmbH Panasonic Testing Centre Winsbergring 15, 22525 Hamburg, Nemčija</p>
Suomi	<p>Valmistaja: Panasonic Projector & Display Corporation 2-15 Matsuba-cho, Kadoma City, Osaka 571-8503, Japani</p> <p>Maahantuoja: Panasonic Connect Europe GmbH Hagenauer Strasse 43, 65203 Wiesbaden, Saksa</p> <p>Valtuutettu edustaja EU:ssa: Panasonic Connect Europe GmbH Panasonic Testing Centre Winsbergring 15, 22525 Hampuri, Saksa</p>
Svenska	<p>Tillverkad av: Panasonic Projector & Display Corporation 2-15 Matsuba-cho, Kadoma City, Osaka 571-8503, Japan</p> <p>Importör: Panasonic Connect Europe GmbH Hagenauer Strasse 43, 65203 Wiesbaden, Tyskland</p> <p>Auktoriserad representant i EU: Panasonic Connect Europe GmbH Panasonic Testing Centre Winsbergring 15, 22525 Hamburg, Tyskland</p>
Türkçe	<p>Tarafından Üretilmiştir: Panasonic Projector & Display Corporation 2-15 Matsuba-cho, Kadoma City, Osaka 571-8503, Japonya</p> <p>İthalatçı: Panasonic Connect Europe GmbH Hagenauer Strasse 43, 65203 Wiesbaden, Almanya</p> <p>AB Yetkili Temsilcisi: Panasonic Connect Europe GmbH Panasonic Testing Centre Winsbergring 15, 22525 Hamburg, Almanya</p>

Product Information (for Turkey only)

AEEE Yönetmeliğine Uygundur.

Environment care information for users in China



This symbol is only valid in China.

Manufactured by:

Panasonic Projector & Display Corporation
2-15 Matsuba-cho, Kadoma City, Osaka 571-8503, Japan

Importer:

Panasonic Connect Europe GmbH
Hagenauer Strasse 43, 65203 Wiesbaden, Germany

Authorized Representative in EU:

Panasonic Connect Europe GmbH
Panasonic Testing Centre
Winsbergring 15, 22525 Hamburg, Germany

Importer for UK;

Panasonic Connect UK,
a branch of Panasonic Connect Europe GmbH,
Maxis 2, Western Road, Bracknell, Berkshire, RG12 1RT



Panasonic Projector & Display Corporation

Web Site : <https://docs.connect.panasonic.com/projector>

© Panasonic Projector & Display Corporation 2026

Panasonic Projector & Display Americas LLC

Two Riverfront Plaza, Newark, NJ 07102

TEL: +1-201-348-7000